



Port Infrastructure Modernization

Erik Soderberg, Liftech President, CA SE

Steven Martinez, Liftech Sr. Mechanical Engineer, CA ME

Good afternoon, everyone. I am Erik Soderberg. I have been working for 29 years as a structural engineer with emphasis on container handling equipment, cranes, wharves, floats, and heavy lifts. My work has resulted in a general knowledge of machinery and electrical systems.

I have worked on the design and evaluation of dozens of wharves including the Guam F5 wharf, Port of Oakland Berths 57-59, Port of Oakland Berth 30 Extension and Berths 32 and 33 Retrofit, Cemex West Sacramento Cement Import Terminal, Redwood City Wharves 1 and 2, and the Port Everglades new Crane Girder System at Southport, which is shown in the photograph on this slide with the new low profile container cranes that use it.

Presentation Organization

Ship size changes

STS crane size changes

Sea level rise

Vessel electrification – cold ironing

Yard equipment upgrades

Power system upgrades

2 of 48

Liftech
LIFTECH CONSULTANTS INC.

I have organized the presentation to present common reasons for needing to modernize or upgrade and then will present some of the common upgrades required.



The most common and significant change resulting in port upgrades has been increases in ship size.

Ship Size Growth

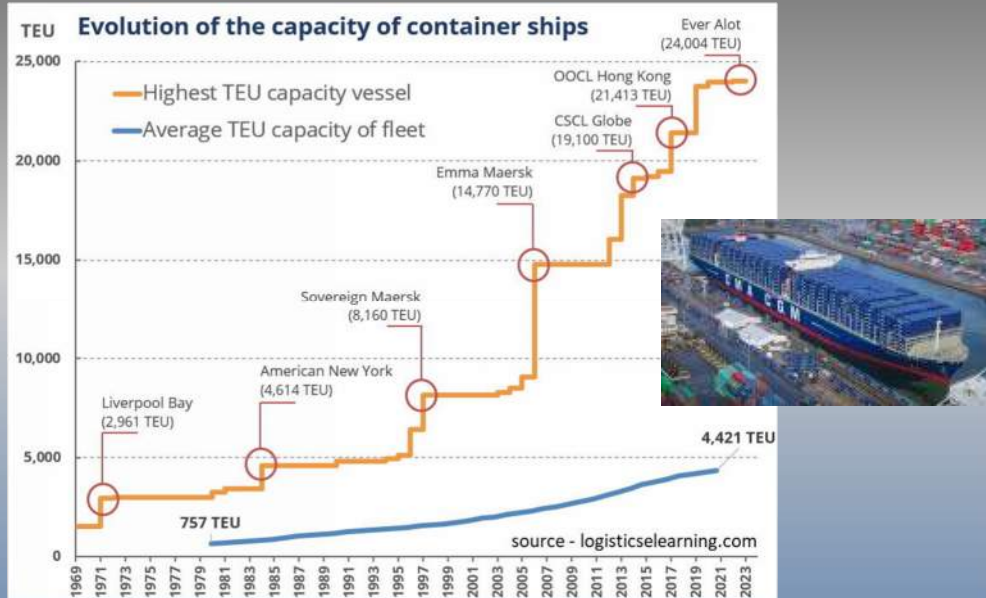

Source LogisticseLearning.com

4 of 48

Liftech
LIFTECH CONSULTANTS INC.

This is a graph of container ship sizes and the year the ships were built.

The largest container ships are now around 24,000 TEU capacity and 23 containers wide.

Even though the largest ships only call at certain ports, there is also a trickle-down effect with smaller ports servicing larger ships.

Berth Space

Some berths require additional length – a costly option

Less costly

Install compact crane stops closer to the wharf end

Add a mooring dolphin beyond the wharf (see next slide)



5 of 48

Liftech
LIFTECH CONSULTANTS INC.

With the larger and longer ships, some existing berths require additional length—a costly option.

Some additional STS crane travel length can often be obtained with relatively little cost by installing more compact crane stops and relocating stops closer to the wharf ends.

For example, the stop on the bottom is 4 ft long. The stop on the right is 6 ft long. Both have enough strength that a runaway container crane will tip over the stop before the stop fails.

Both stop designs are rounded to help limit damage to yard equipment during accidental collisions.

Mooring Dolphin

Add a mooring dolphin beyond the wharf so the vessel can be located closer to the wharf end.

Mooring Dolphin at IMTT Port of Richmond



6 of 48

Liftech
LIFTECH CONSULTANTS INC.

If a larger ship will be too close to the end of the wharf, if practical, adding a mooring dolphin beyond the wharf is a low-cost option to accommodate breasting lines.

Berthing Fenders



7 of 48

Liftech
LIFTECH CONSULTANTS INC.

The fender energy required for ship berthing is due to the ship mass and its velocity perpendicular to the wharf when berthing.

Larger ships have a smaller berthing velocity than smaller ships. Since energy is proportional to velocity squared, the additional energy required for larger ships is more, but not a lot more. Sometimes existing fender systems can be justified for larger ship sizes.

If replacing fender systems, if practical, use deeper fenders to limit the fender reaction on the wharf and ship. If larger fender reactions result, confirm that the wharf structure is adequate. Typically, only local strengthening of the wharf is required, at a moderate cost.

Berthing Fenders

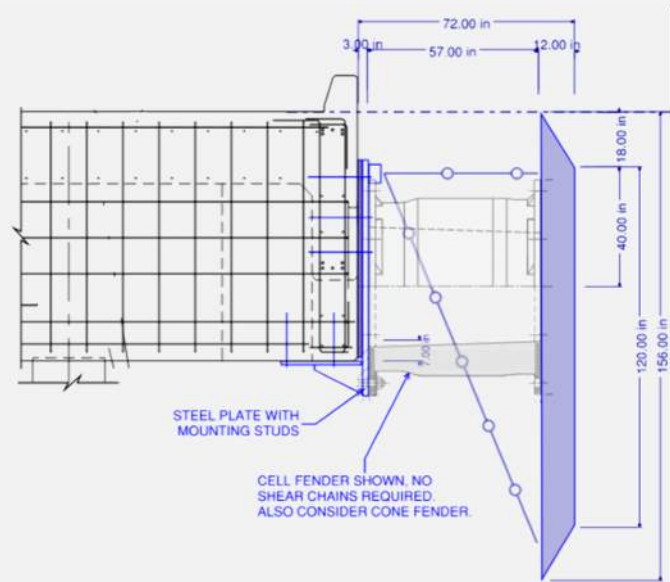

8 of 48

Liftech
LIFTECH CONSULTANTS INC.

This is a concept design for a new fender system that is larger than the one it replaces. As shown, it does not easily fit onto the existing wharf, a common challenge. Fitting larger fenders onto relatively smaller wharf faces is typically addressed by mounting the fender on a steel bracket, which is then bolted onto the wharf as shown in this arrangement.

Berthing Fenders

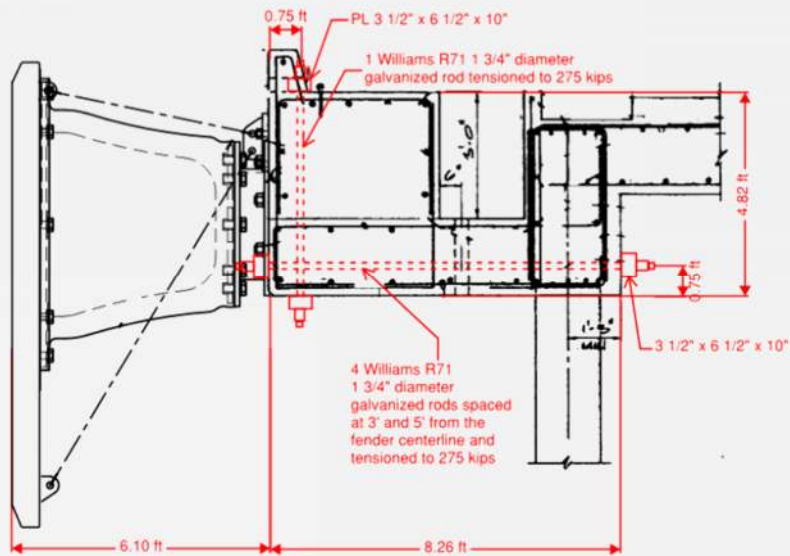

9 of 48

Liftech
LIFTECH CONSULTANTS INC.

If the wharf structure needs to be strengthened, typically only localized strengthening of the wharf is required, which is practical with drilling and installing high strength reinforcing rods as shown in this concept.

Bollards



10 of 48

Liftech
LIFTECH CONSULTANTS INC.

Increased mooring forces typically require stronger bollards. Installing stronger bollards requires relatively little cost unless the wharf structure needs strengthening.

Arrangement and Bitt Loading



Source www.bigstock.com - 165277886



Source alamy.com - BT1B6K

11 of 48



Liftech
LIFTECH CONSULTANTS INC.

When sizing bollards, consider probable mooring line arrangements, not the preferred or favorable arrangement.

As shown in these photographs, sometimes many or all lines are placed around the bollard and, as shown in some of the photos, even only one bitt of a double bitt bollard.

Be aware that for double bitt bollards, as shown in the lower left images, the bitt load rating is half that of the bollard. For example, a 200 metric ton (tonne) double bitt bollard has a bitt rated load capacity of 100 t. Determine what loading is required for each bitt based on probable mooring line layouts.

Some ports, such as the Port of Long Beach, use single bitt bollards to avoid having too many mooring lines on one bitt of a two-bitt bollard.

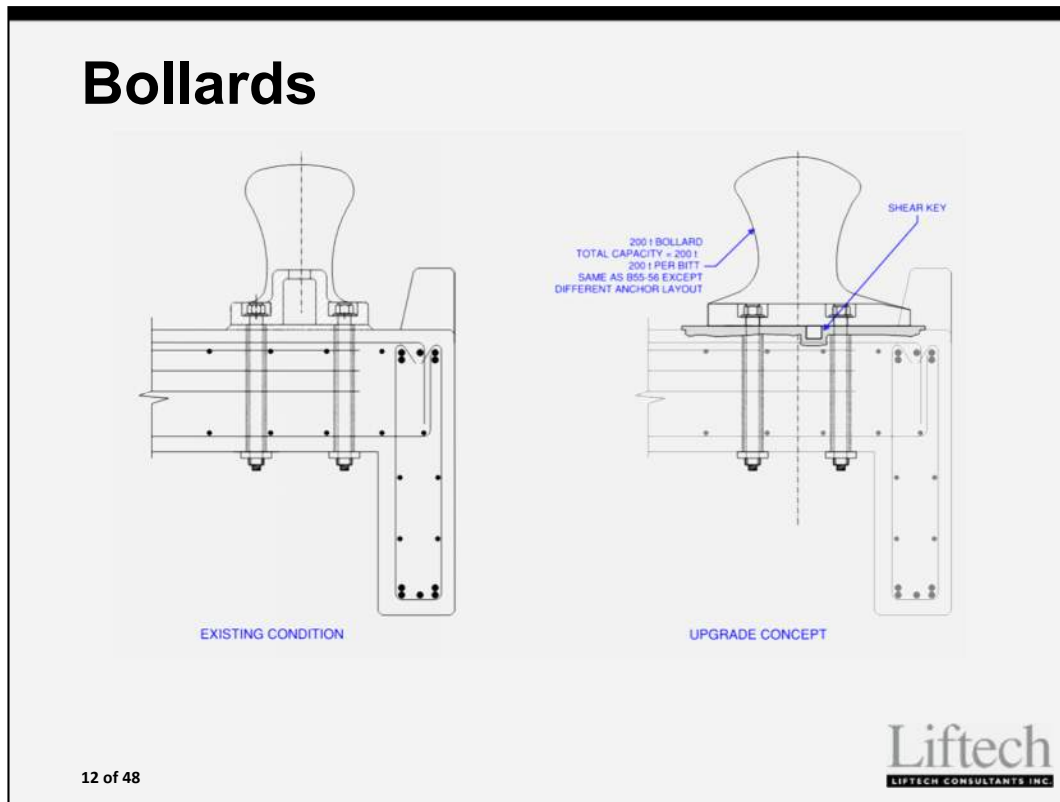

When upgrading bollards, be sure the engineer considers all options. For example, in the upgrade concept shown here, the existing anchors were adequate for upgrading to a 200 t capacity bollard by using a custom bollard geometry with a wide base, as shown on the right, to limit the tension that develops in the anchors.

Reusing existing anchors will save significant cost.

The cost of a custom bollard is small.

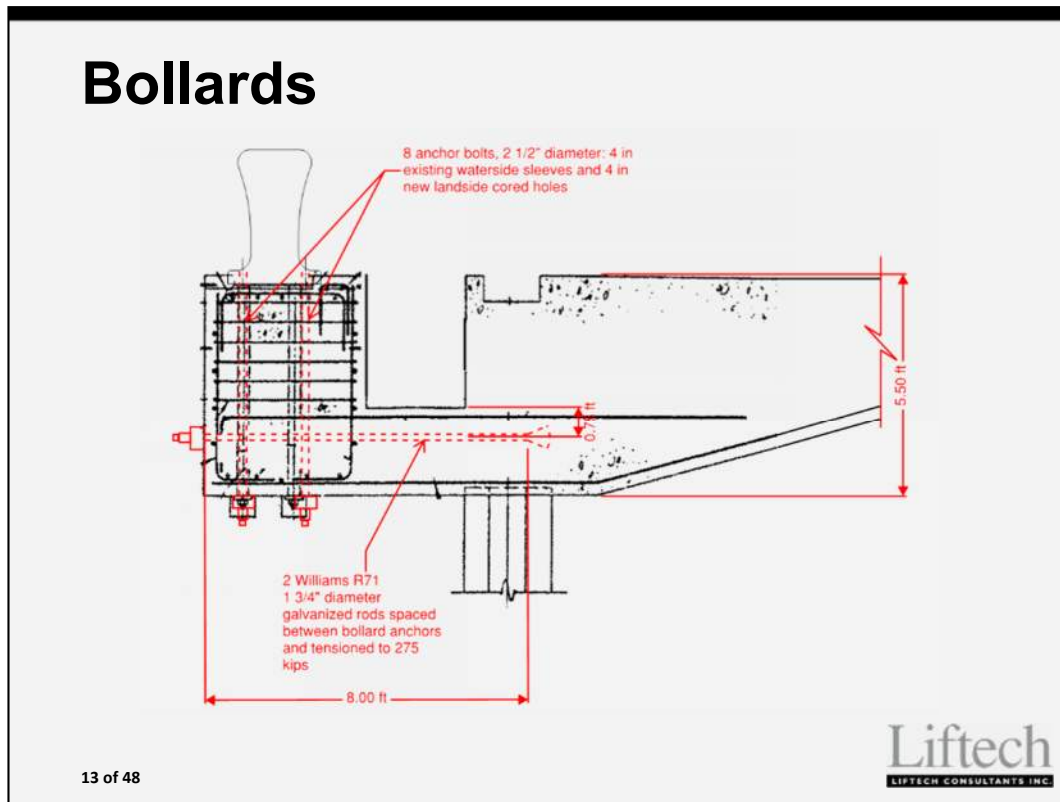

Like the local strengthening at new fender locations with larger design reactions, local strengthening for larger bollard loads can typically be limited to drilling and installing high strength reinforcing as shown in this slide.

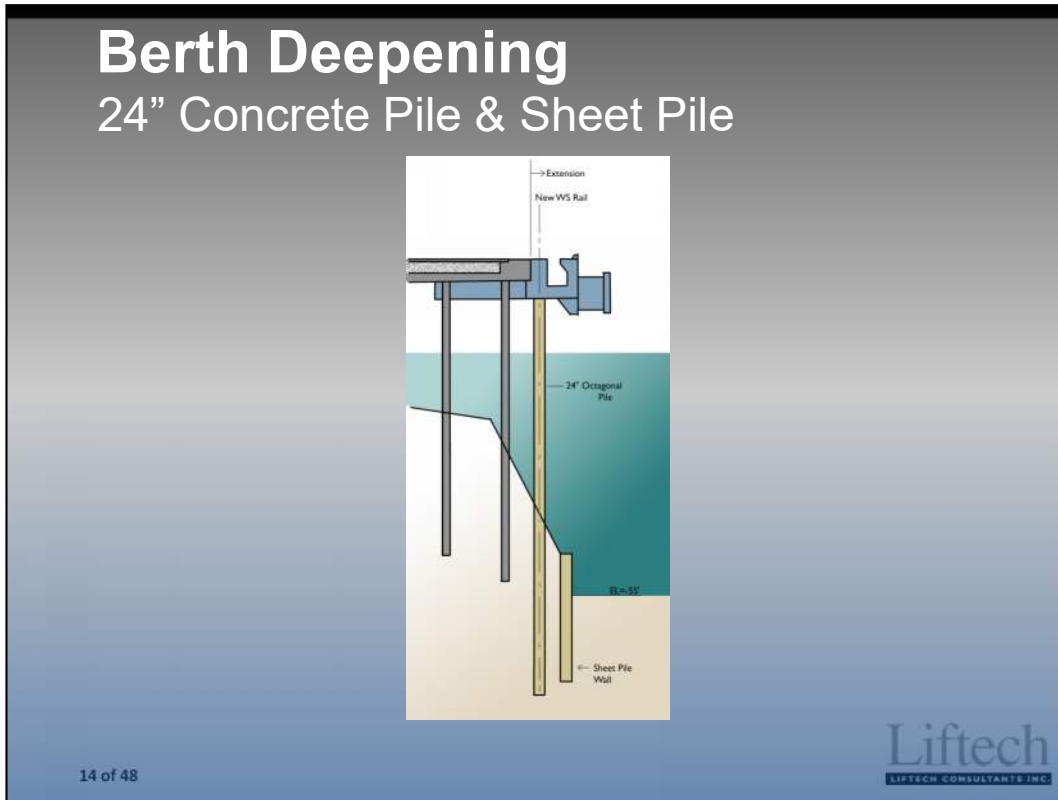

Increasing the berth depth will affect the wharf embankment and its stability. Typical modifications to deepen the berth include driving sheet piling to retain the embankment and permit the deeper dredging.

This slide shows the Liftech design implemented at Port of Oakland Berths 32 and 33. The design involved removing the waterside edge of the wharf, driving a sheet pile toe wall to retain the embankment after dredging, and then building the new waterside edge of the wharf including new pile, new stronger crane girder system, stronger bollards, and larger energy fenders.

Berth Depth

Steel Pile and Sheet Pile System

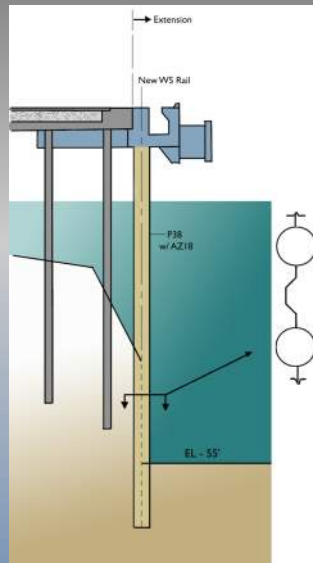

15 of 48

Liftech
LIFTECH CONSULTANTS INC.

This is another option that was considered for the Port of Oakland Berths 32 and 33 modernization involving a combi-wall with the round king piles supporting both the embankment toe sheets and the crane girder.



When ship size increases, often increases to crane sizes are required.

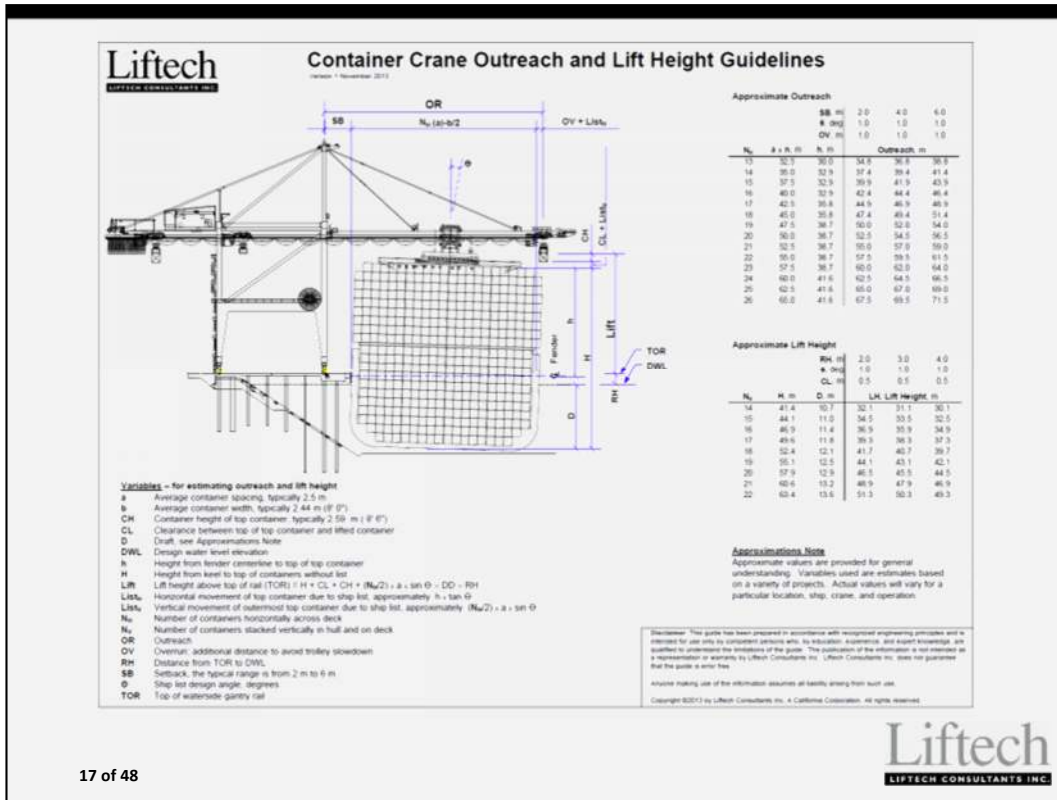

17 of 48

To determine what size crane is required involves a variety of factors such as vessel geometry, wharf elevation, crane setback, and others as shown in this slide. This slide is available on our website.

Crane Modifications



Crane Raise

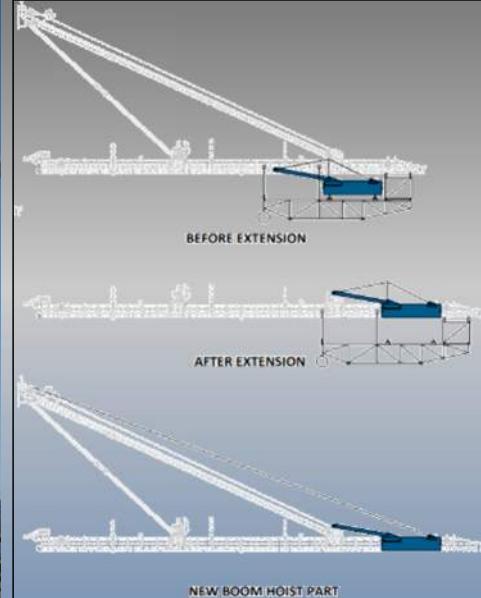

Boom Extension

18 of 48

Liftech
LIFTECH CONSULTANTS INC.

When larger cranes are required, new cranes can be procured.

It is often practical to modify existing cranes by raising the crane, extending the boom, or both.

A crane raised on a jacking system is shown on the left.

A boom extension system not requiring removal of the boom is shown on the right.

Both of the systems shown are currently being used.

Wheel Loads

Wheel loads may exceed the design or rated capacity of existing wharf girders.

Options to address excessive crane loads include:

- Optimize crane design
- Analyze or load test structure & foundation (*see next slide*)
- Strengthen existing girders
- Replace girder systems with new, stronger systems
- Increase crane rail gage for new cranes



Larger cranes result in larger crane wheel loads.

Wheel loads may exceed the rated capacity of existing wharf girders.

Options to address excessive crane loads include:

Option 1: Optimizing the crane design to reduce crane loads, balance the crane loads between the landside and waterside wheels to better suit the available landside and waterside girder capacities, or both. This option is only worthwhile if the existing crane wheel loads are not significantly greater than the girder's rated capacity.

Option 2: Analyzing or load testing the existing structure and foundation to justify increasing the rated capacity.

Option 3: Strengthening the existing crane girder system.

Option 4: Replacing girder systems with new, stronger systems.

Option 5: Increasing the crane rail gage will reduce wheel loads. Additionally, it is often less costly to build a new landside girder than to try to strengthen or replace both existing girders.

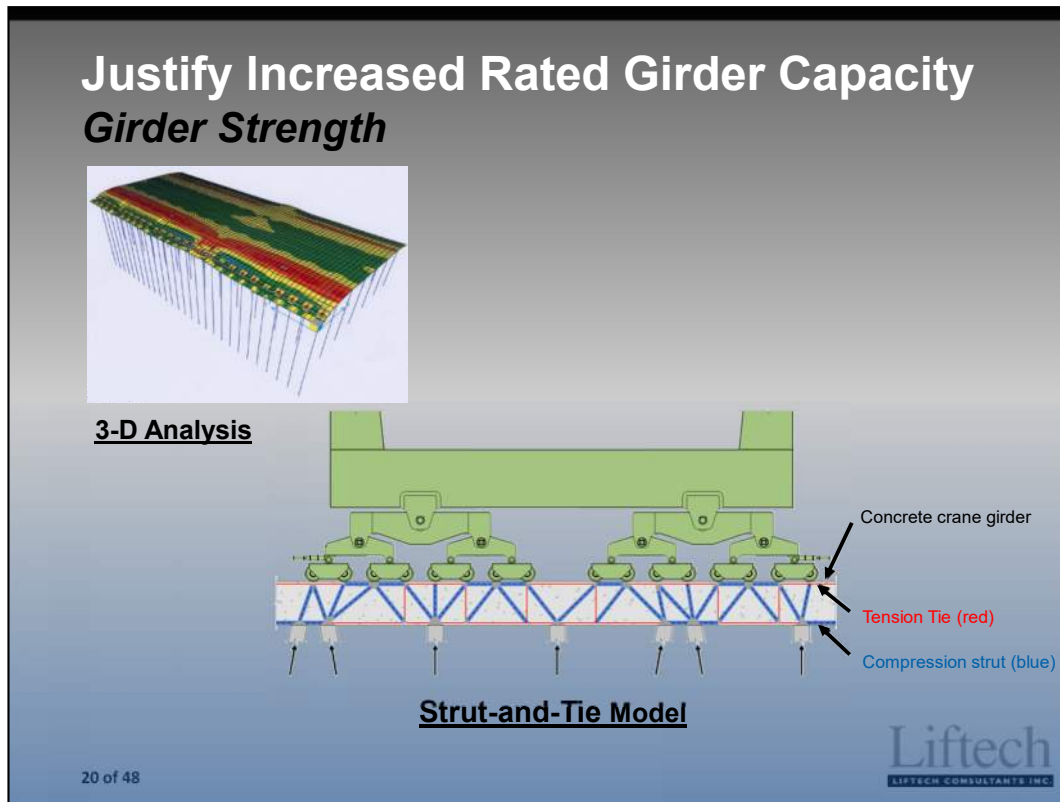

We have evaluated many existing wharves. In most cases, larger rated girder capacities can be justified by analyzing the girder system using modern methods.

Finite element analyses, as shown in the upper left image, are particularly worthwhile when the girder is integrated into a wharf deck or if the wharf superstructure has cross beams, both resulting in load distribution into the rest of the wharf structure.

Strut-and-tie analysis, as shown in the lower right image, is worthwhile when the shear strength calculated using more conventional methods is inadequate.

There are other methods available.

The engineering costs to evaluate an existing girder structure are a fraction of strengthening costs, and some of the engineering effort can be applied to a strengthening design if it is needed.

A feasibility study by a structural engineer is a good first step to decide if this approach is practical.

Justify Increased Rated Girder Capacity

Piling Capacity

Analyze pile driving records
Pile dynamic analysis through testing
Load test

The diagram illustrates a pile load test arrangement and a detailed view of the test setup. The left side shows a crane girder system with a load test arrangement, including a crane, rail, and pile. The right side shows a detailed view of the pile load test, including an equalizer beam, beam, rail, rail girder, jack beam, and test pile.

Pile Load Test Arrangement

Pile Load Test Detail

Labels in the detail view: EQUILIZER BEAM, BEAM, RAIL, RAIL GIRDER, JACK BEAM, TEST PILE.

21 of 48

Liftech
LIFTECH CONSULTANTS INC.

If the crane girder system's capacity is limited by pile soil capacity, larger pile capacities can be studied by analyzing pile driving records, performing load tests as shown in this slide, or by performing dynamic load testing by striking the top of the pile with an impact hammer and measuring the pile response.

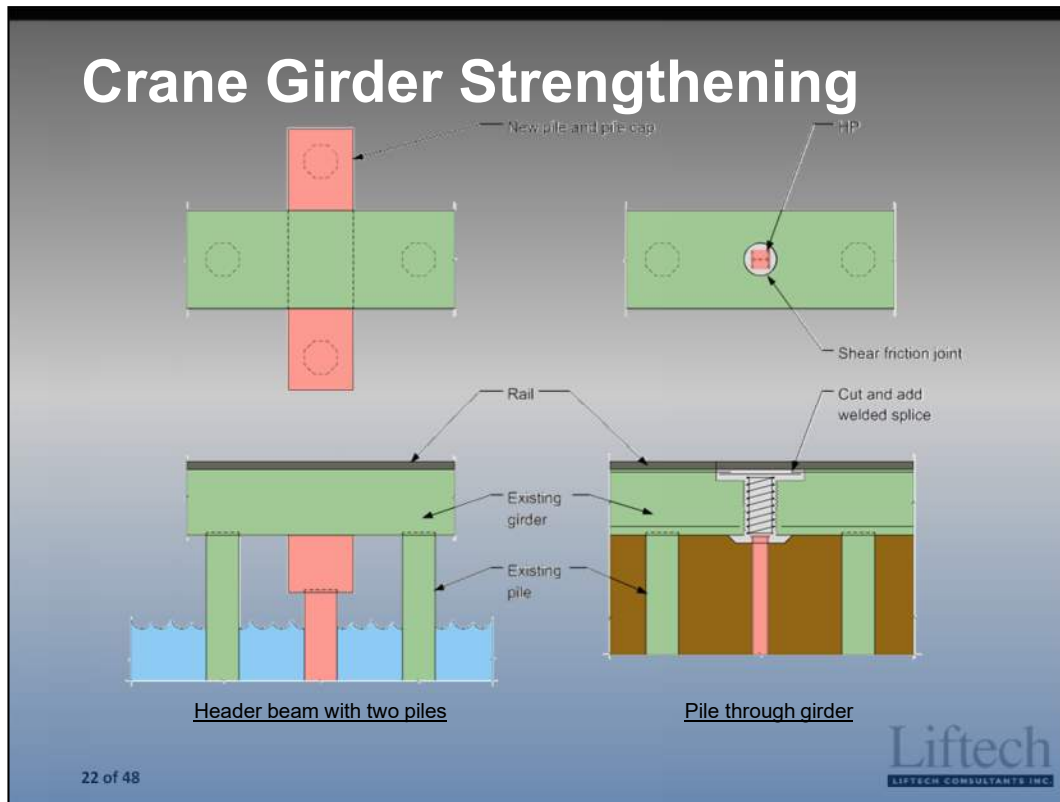

If needed, crane girder strengthening can be accomplished in many ways. A common method shown on the left images is to drive piles on either side of the girder and install a header beam between them. The approach on the right involves drilling a hole through an existing girder, driving a new pile, roughening the hole, and filling it with cement. The substantial longitudinal girder reinforcing will provide the required confinement forces for the concrete plug shear transfer into the girder.

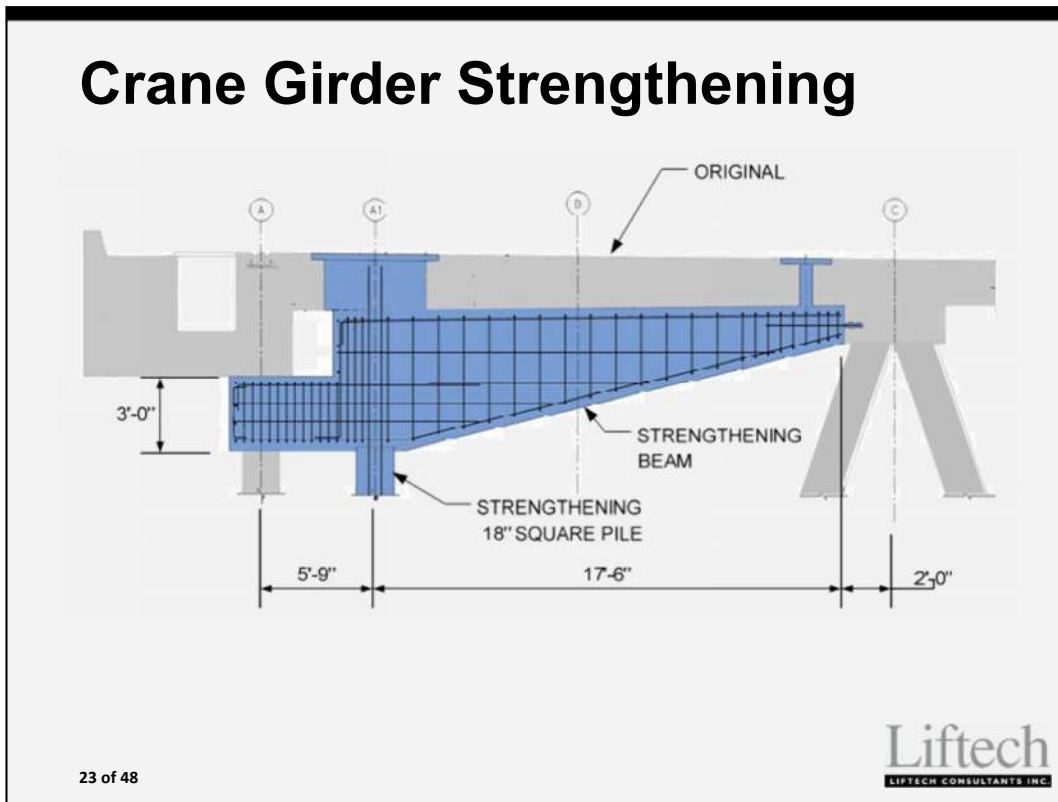

A practical strengthening method used at the Port of Oakland Berth 25 involved driving a new pile through the wharf deck and connecting under the waterside crane girder with an underdeck transverse beam, all shown in blue.

Crane Stowage Hardware



24 of 48

Liftech
LIFTECH CONSULTANTS INC.

Installing stronger crane stowage hardware is typically practical.

A new crane stowage pin socket is shown on the left. This new socket was connected to the side of the existing girder with high strength bolts inserted through holes drilled through the girder.

The new crane tie-down linkage assembly shown on the right was also connected to the girder using high strength through bolts that are not observable due to concrete cast over the lower portion of the assembly.

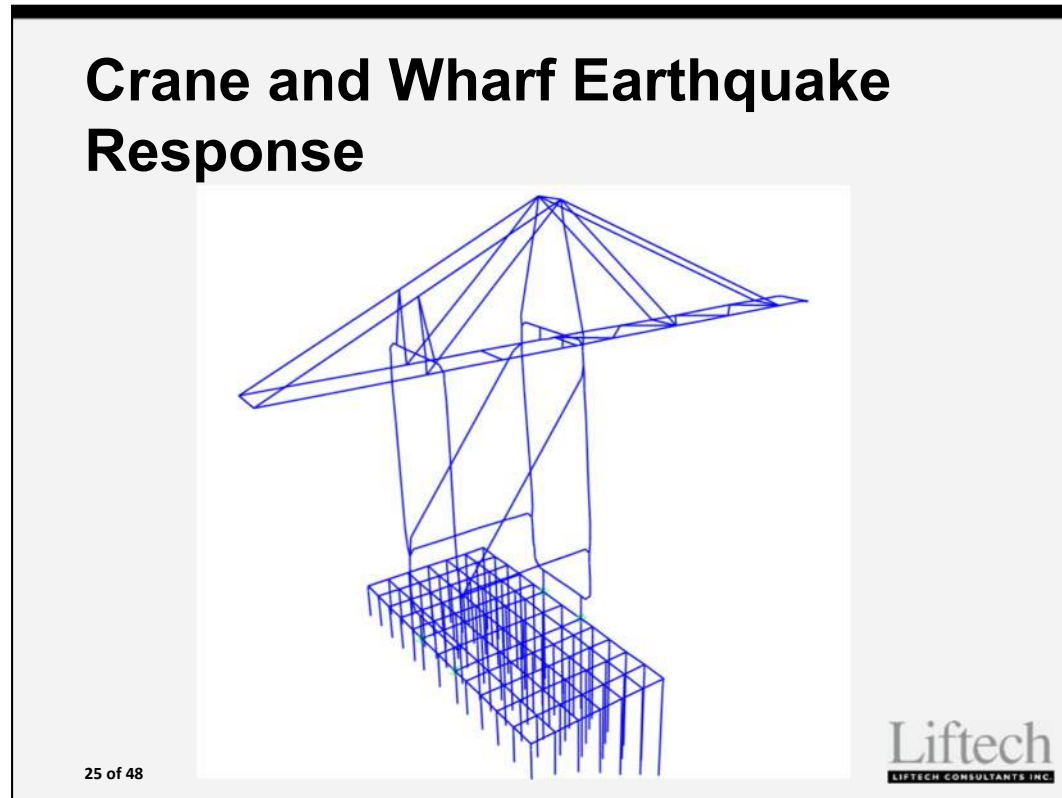

Larger STS cranes will more significantly affect the wharf response in large earthquakes.

This video is a finite element time history analysis in which an Alaskan design earthquake ground motion is applied to a proposed future wharf and future crane.

Using modern finite element software, it is practical to analyze the response of the crane and wharf with reasonable accuracy, allowing for critical design decisions to be made for the crane and wharf designs.



Sea level rise is a growing issue affecting port modernization.

Sea Level Prediction

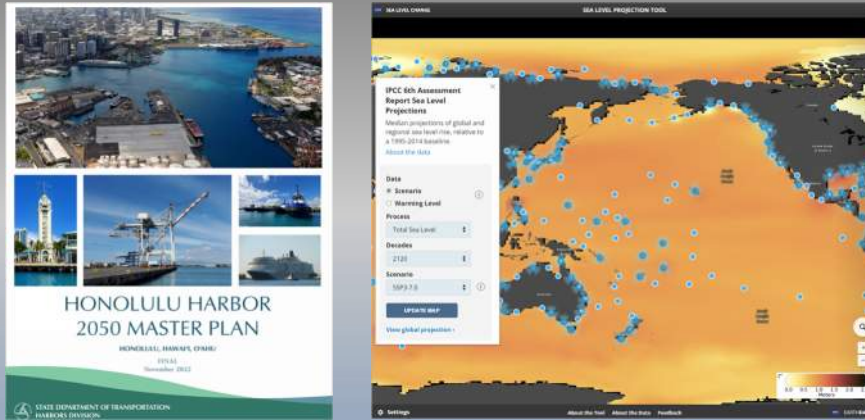

Source: sealevel.nasa.gov

27 of 48

Liftech
LIFTECH CONSULTANTS INC.

Sea level rise will vary from location to location. Estimates for most locations are now readily available. Local plans typically provide estimates as well as guidance on what values are reasonable or required to design for. There are many other sources available, such as the web-based tool available from NASA shown on the right.

Sea Level Upgrades



Current Pier Pile Connections

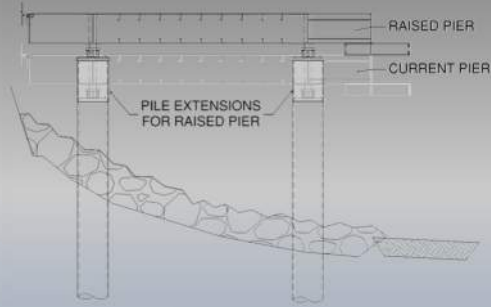

Section View – Current and Raised Pier

28 of 48

Liftech
LIFTECH CONSULTANTS INC.

Modernizing for sea level rise is a significant challenge.

Upgrades to date typically involve rebuilding a wharf to a higher elevation when a rebuild is required for other reasons, such as for much larger crane wheel loads.

The images on this slide show a Liftech design of a new steel pier along the San Francisco shoreline where the superstructure can be removed, the piles extended, and the superstructure reconnected.

There are no easy answers to this growing problem.



Reducing air pollutants and carbon dioxide is another goal resulting in modernization. I will first talk about providing electric shore power to vessels.

Vessel At-Berth Regulations



30 of 48

Liftech
LIFTECH CONSULTANTS INC.

Many ports of call now require “zero emissions” for berthed vessels, necessitating that vessels are plugged in and the engines shut down. For example, California’s ‘At Berth’ regulations are legislated by the California Air Resources Board (CARB) and are being phased into different vessel sectors.

Vessel power demand varies, but typically numbers are 4 MVA or megawatts for RoRo and Ferry ships, 7.5 MVA for large container ships, and up to 20 MVA for large cruise ships (WBCSD, Port of Vancouver).

Shore Power Considerations

Substation/feeder capacity

Trenching and conduit routing

Berthing arrangements

Power demand

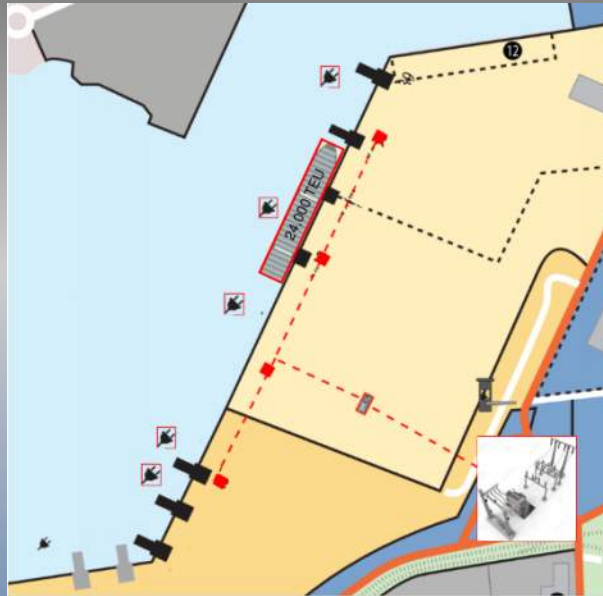

31 of 48

Liftech
LIFTECH CONSULTANTS INC.

Shore power upgrades are often a large civil and electrical project involving multiple stakeholders. Vessel shore power is delivered at unique voltages, 6.6kV or 11kV, and require separate substation feeds from other than existing port infrastructure. It is common that existing infrastructure does not have the hardware to deliver the power, requiring additional substation equipment and circuits.

Fixed Connection Locations



32 of 48

Liftech
LIFTECH CONSULTANTS INC.

Shore power cables are required to hang nearly plumb from the vessel connection location. So, the vessel's plug-in location along its length must align with fixed vaults on the wharf. As a result, fixed wharf connection locations need to be carefully determined.

Mobile Shore Power Connections

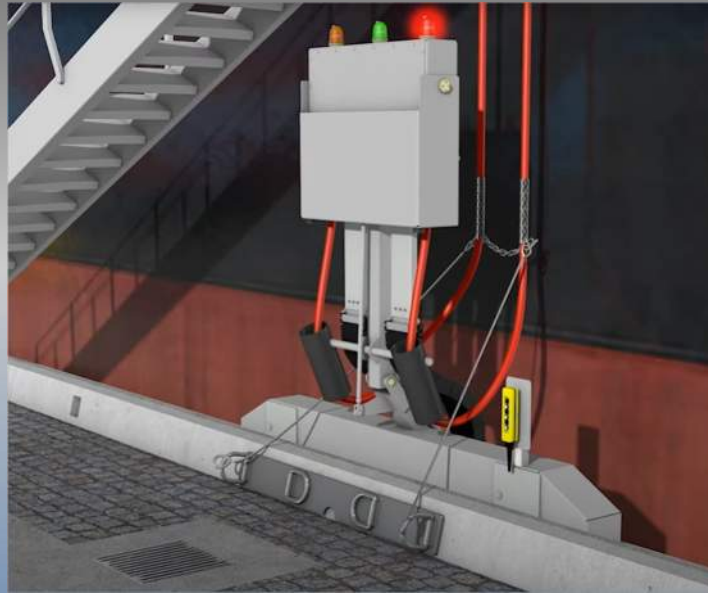

Source: Igus

33 of 48

Liftech
LIFTECH CONSULTANTS INC.

There are new mobile shore power systems, such as the one shown here by IGUS, that travel along the wharf face. Such systems have been implemented in Europe and are being considered elsewhere including at the Port of Oakland. With these systems, power can be delivered to the vessel anywhere along the system's track.



Next, I will present some of the larger upgrades to the yard due to modernization.



In addition to operational changes, there is increased interest in reducing yard equipment emissions.

Primarily for this reason, RMG cranes are becoming more common. Such projects require increased planning and coordination among civil, mechanical, and electrical design teams.

RMG cranes require structural and electrical infrastructure upgrades with construction of rails supported on at grade girders, and increased power and power distribution to the equipment.

Yard Upgrades—Battery Power



Source: LBCT



Source: P2S



Source: Konecranes

36 of 48

Liftech
LIFTECH CONSULTANTS INC.

Other modernization includes converting to “zero emission” equipment such as the battery powered Automated Guided Vehicles, also called AGVs, at Long Beach Container Terminal (LBCT). This system required the construction of battery charging warehouses.

Yard Upgrades—Alternative Fuels



Source: Container-News.com

37 of 48

Liftech
LIFTECH CONSULTANTS INC.

In addition to electrification, alternative fuels are being considered as a viable long-term solution for zero emissions. Hydrogen is currently considered the leading fuel, offering comparable energy density with diesel. Hydrogen's challenges relate to the large and complex infrastructure required for manufacturing and distribution, and logistical challenges such as storage, delivery, and pumping. While the technology for using hydrogen is advancing, it has not yet fully matured for widespread commercial use in the maritime sector, with development ongoing and limited implementation.

This is a photograph of a hydrogen filling station at Container Terminal Tollerort, CCT, at the Port of Hamburg.

Liftech is part of a team of engineers studying hydrogen as an alternative fuel for future yard RTG cranes and all other container handling equipment.



As discussed, many modernization upgrades being considered require increased electrical power to a terminal.

In this section, I will present some of the issues to consider with electrical power system upgrades.

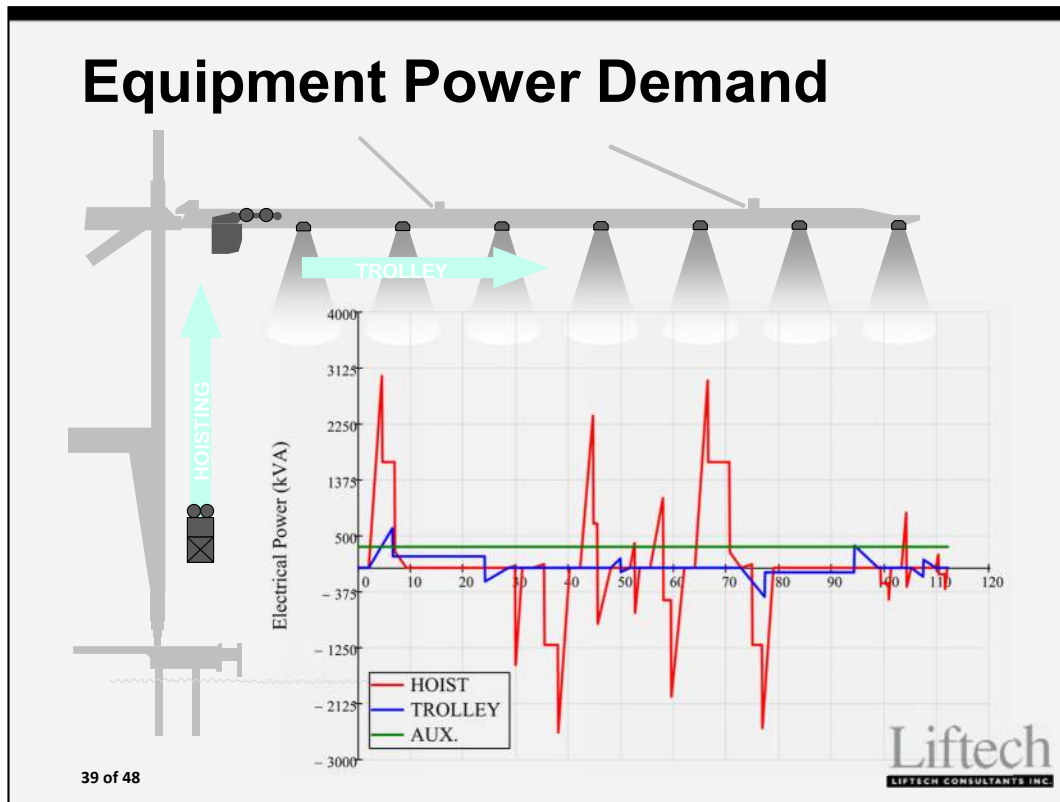

Determining how much additional power is required for added electrically powered equipment is complicated.

Container handling equipment has a unique electrical power demand profile, unlike most other industrial equipment.

A crane's operating duty cycle imposes large and varying electrical loads, with peak draw and regeneration values 200 to 300% greater than the nominal demand, and much greater than the average demand.

Summing motor nameplate rated power is typical across many industries to determine required additional power but is not suitable for container handling equipment.

Multiple Crane Demand

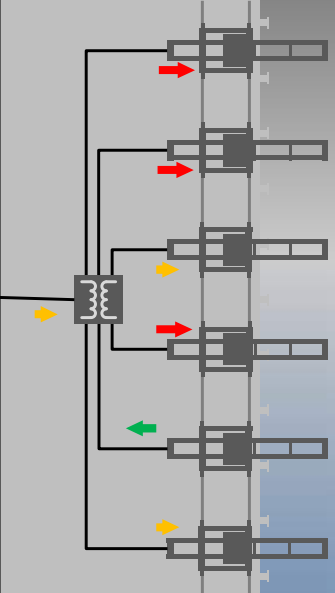

Plan View

40 of 48

Liftech
LIFTECH CONSULTANTS INC.

NEC 610 based on motor nameplates—not appropriate

Recommendation:
Develop model based on crane principles of demand diversity

With multiple cranes connected to one feeder, total demand is estimated using complex electrical models based on usage or demand diversity. For example, with many cranes, it is unlikely that all cranes will hoist rated loads at the same time. It is reasonable to expect that not all cranes are at their same point in the loading or unloading cycle. For example, regeneration of one crane will offset the draw of another.

This is illustrated in this slide by three cranes with red arrows drawing significant power, two with yellow arrows drawing a little, and one green arrow regenerating a lot while lowering a heavy container. As shown by the yellow arrow at the transformer, in sum the cranes are drawing a moderate amount of power, not six times the maximum crane power.

Liftech's power demand studies include electrical modeling of multiple cranes on a circuit considering the diversity of crane operations and power demand and regeneration.

Duty cycle simulations and electrical models vary based on the composition of equipment. For example, yard equipment has more horizontal than vertical motion. Simulations are needed to determine the specific diversity factors for various terminal and equipment configurations.

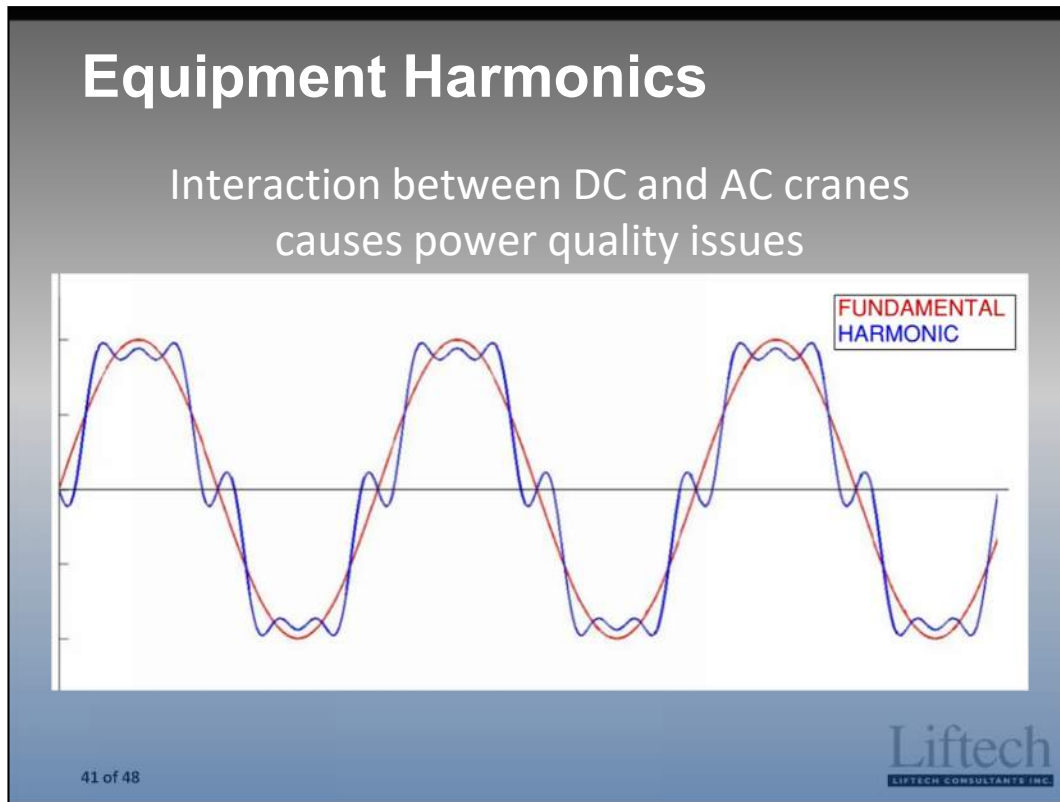

Older container equipment was typically DC (direct current) prior to the mid 2000s. All modern cranes use variable frequency AC technology. Adding AC (alternating current) cranes to a circuit with DC cranes can cause problems and should be carefully studied as DC cranes are “noisy” or “dirty,” especially when pushing regenerative power back into the circuit. Sometimes power factor correction and harmonic filtering are required.

Feeder Equipment Sizing

RMS Power

5 min or 15 min demand
Heating and sizing of electrical
components

Peak Current

1 s or 5 s demand
Voltage drop and
impedance of transformers
and conductors



Must Consider Both!

42 of 48

Liftech
LIFTECH CONSULTANTS INC.

When working with the utilities supplying the power, it is critical to coordinate on several key aspects of the power demand. RMS power is the average sustained draw over 5 to 15 minutes. RMS demand determines the heating and sizing of electrical components.

Peak Amperage demand is typically measured in the range of 1 to 5 second intervals, and determines the voltage drop and impedance of the transformers and conductors. It is critical for the upstream electrical supply to consider both RMS and Peak demand profiles. As a reminder, peak current can be 2 to 3 times the nominal motor power rating.

Undersized components can cause overheating, voltage dips or spikes, and shutdowns.

Voltage drops of more than 10 to 15% cause circuit breaker trips and potential damage. Overvoltage spikes of more than 10% during regeneration also cause issues.

It is important to understand these concepts to ensure appropriately sized transformers and conductors are used with low impedance to prevent trips during peak current draw.

Power System Upgrade Overview



43 of 48

**Liftech**
LIFTECH CONSULTANTS INC.

Images of installing additional power for six new cranes for the modernization of the Port Everglades Southport terminal are shown on this and the next slide.

In the upper image, a new maintenance building was constructed. New electrical switchgear was installed in part of this building as shown in the lower image. Off terminal power from the utility was brought into the building and the switchgear.

Power System Upgrade Overview



44 of 48

Liftech
LIFTECH CONSULTANTS INC.

New power lines were run from the new switchgear and maintenance building to new crane plug-in vaults along the wharf.

Directional boring was performed to run the new lines under active container yards as shown in the upper left image.

Utility lines that exited the directional boring at the wharf are shown in the upper middle image.

Trenched utilities running to the wharf are shown in the upper right image.

Lastly, the power was connected into new crane vaults shown in the bottom image.

Terminal Micro Grids



45 of 48

Liftech
LIFTECH CONSULTANTS INC.

Another potential power upgrade involves micro grids.

Micro grids are a localized solution typically for addressing concerns related to utility power delivery or reliability.

They are useful for peak shaving, storing regenerative power, improving power quality and stabilizing the power factor, and reducing power harmonic issues.

Additionally, micro grids can function as emergency backup power with the addition of standby generators, ensuring port operations remain resilient and reducing power fluctuations or outages. Micro grids can be augmented with renewable energy such as solar or green hydrogen.

The micro grid shown in the image is a diesel fuel powered backup system that Liftech designed for Freeport in the Bahamas to provide full capacity power for 10 days: 12 megawatt system – (6) containerized 2 megawatt generators, (10) fuel containers for 600,000 liters or 160,000 gallons of diesel, transformers and switchgear are blue. The system had automatic fail over, meaning that it starts automatically, and computerized fuel control.

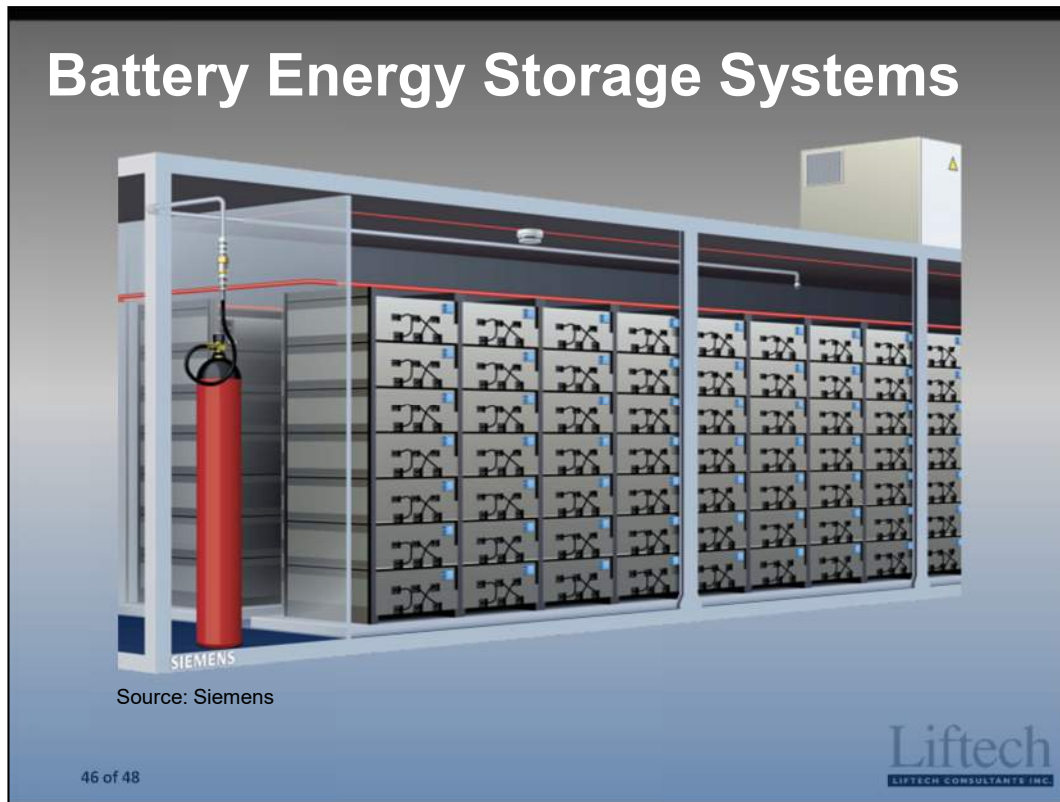

Battery energy storage systems, also known as BESS, can be stand-alone, or function as part of a micro grid. Modern lithium-iron-potassium-oxide known as lithium-iron (LiFePO₄) batteries have more advanced chemistries that are considered less hazardous than older lithium-ion technologies. Battery systems capture and store regenerative power that would otherwise be lost as heat in load banks. They typically charge during low demand, lower cost periods. Sophisticated systems for HVAC, fire detection, and suppression are required, which coordinate to help prevent and mitigate fires.

Battery Energy Storage Systems (BESS) have been considered on multiple Liftech projects. BESS are more worthwhile where there is less reliable utility power supply.

Battery Management Systems (BMS) are an important part of the system for safe charge/discharge and long battery life.

Summary



47 of 48

Liftech
LIFTECH CONSULTANTS INC.

As presented, there are many catalysts for modernization. Current key catalysts include the need to service larger vessels and the change to zero emission power sources. A growing but much longer-term catalyst is sea level rise.

There are issues that must be dealt with for larger vessels and larger cranes that the industry has been dealing with for years, and there are a variety of methods to facilitate modernization.

The issues that must be dealt with for sea level rise are daunting and will require significant upgrades in the future. Any that are practical to do now should be considered, for example, when new wharves or portions of wharves are constructed.

The issues that must be dealt with for new power sources are advancing, with existing alternatives and many more being developed.

Be aware of modernization options as some can significantly reduce costs.



Thanks for attending my presentation and please let me know if you have any questions.

Copyright 2024 by Liftech Consultants Inc. All rights reserved.

This material may not be duplicated without the written consent of Liftech Consultants Inc., except in the form of excerpts or quotations for the purposes of review.

The information included in this presentation may not be altered, copied, or used for any other project without written authorization from Liftech Consultants Inc. Anyone making use of the information assumes all liability arising from such use.

Quality Assurance Review:

Author: Erik Soderberg, Steven Martinez

Editor: Patrick McCarthy, Linda Weber

Principal: Erik Soderberg