

a b c d e f g h

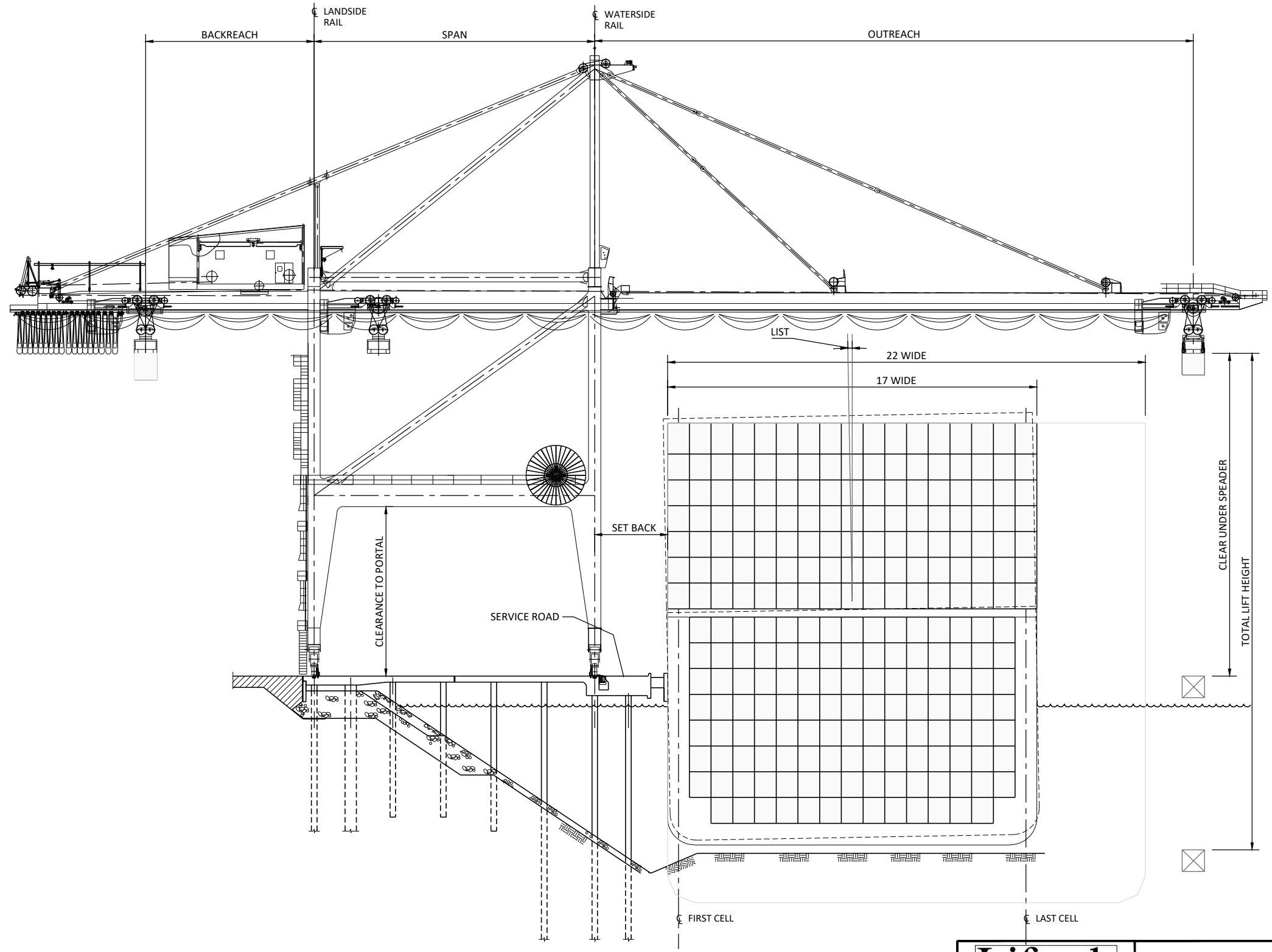
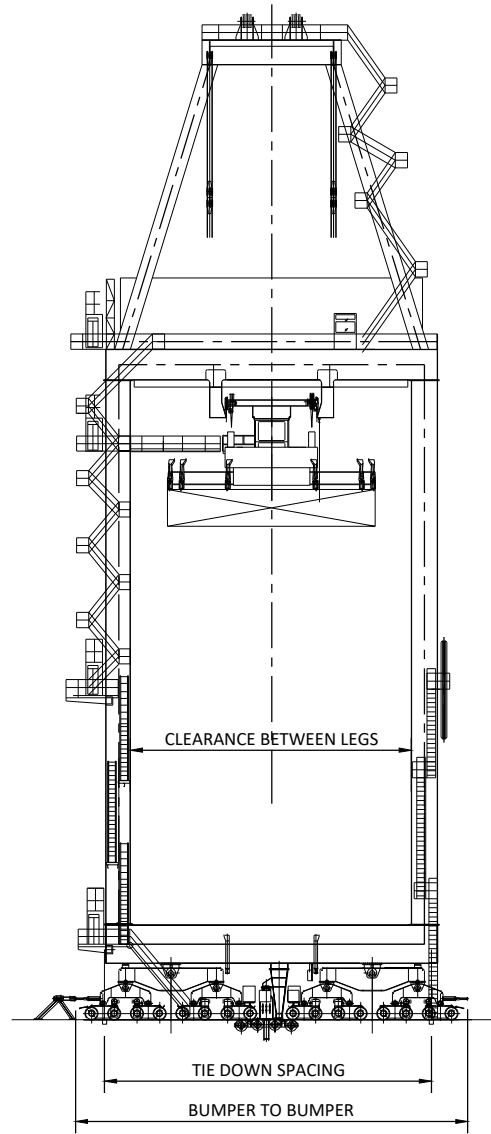

CLEAR UNDER SPREADER

TOTAL LIFT HEIGHT

No.	Revision	Date	By	Checked	Approved
1					
2					

PRINTED  
3/29/2022

**Liftech**  
LIFTECH CONSULTANTS INC.  
344 20th Street, Suite 360  
Oakland, Ca 94612  
Ph: (510) 832-5606

CRANE OPERATING TERMS			
Project No.	J993	Sheet No.	1
By	AH	Checked	ES
Approved	MJ	of	1
Date	9-18-03	Revision	0

1 2 3 4 5 6 7 8