

## **Tandem-40 Dockside Container Cranes and Their Impact on Terminals**

Derrick Lind,<sup>1</sup> Jonathan K. Hsieh,<sup>2</sup> and Michael A. Jordan<sup>3</sup>

<sup>1</sup> Derrick Lind, SE, Associate, Liftech Consultants Inc., 344-20th Street, Suite 360, Oakland, CA 94612; Tel 510-832-5606, Fax 510-832-2436; dlind@liftech.net

<sup>2</sup> Jonathan K. Hsieh, SE, Principal, Liftech Consultants Inc.; jhsieh@liftech.net

<sup>3</sup> Michael A. Jordan, SE, CEO, Liftech Consultants Inc.; mjordan@liftech.net

### **Background**

Conventional single-hoist container cranes have been in use since the mid-sixties. Many innovations have been developed to improve the productivity, including increases in trolley/hoist speeds, cranes with two trolleys, and elevating girder cranes. The latest development is a tandem-40 crane that can handle two 40-foot containers for each lift.

Tandem crane technology has been proven successful. Several ports, including Algeciras, Spain; Antwerp, Belgium; Dubai, U.A.E.; Shanghai, China; and Yantian, China, are now using tandem-40s effectively.

This paper discusses single-hoist tandem-40 (SHT40) and dual-hoist tandem-40 (DHT40) cranes. These cranes pick up two or more containers with a single trolley running on a conventional runway. We compare these cranes to conventional container cranes and discuss tandem crane components, the importance of improved yard operations to accommodate the tandem 40s, impact on wharf structure design, and possible productivity improvements.

### **Crane Configurations**

Crane configurations and terminology are shown in Figure 1. Terms may vary somewhat in the industry, but the terms shown are commonly used.

TANDEM-40 CRANE CONFIGURATIONS

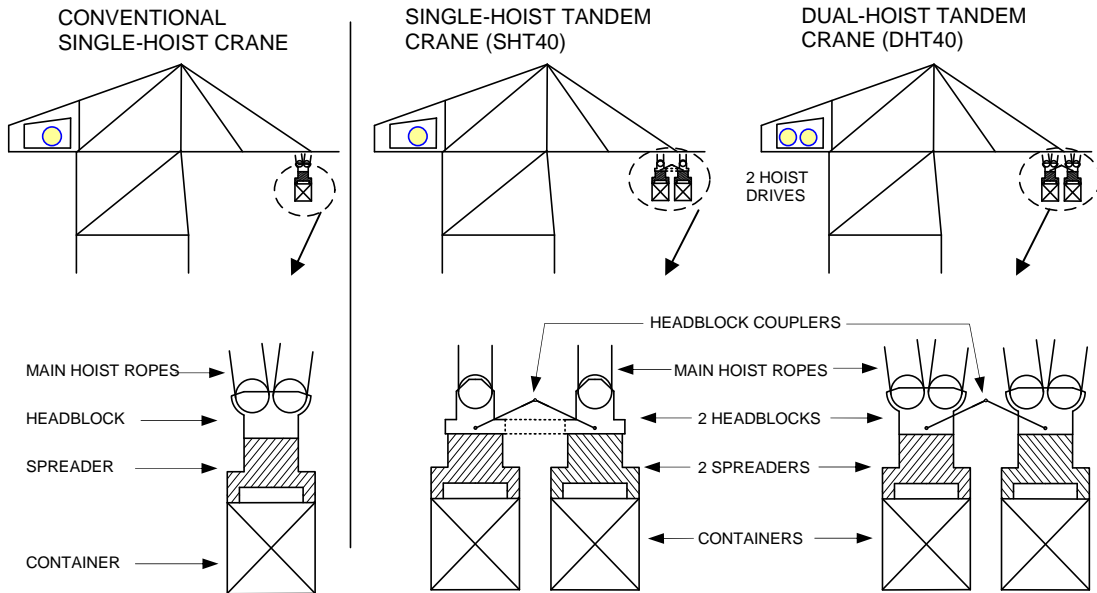
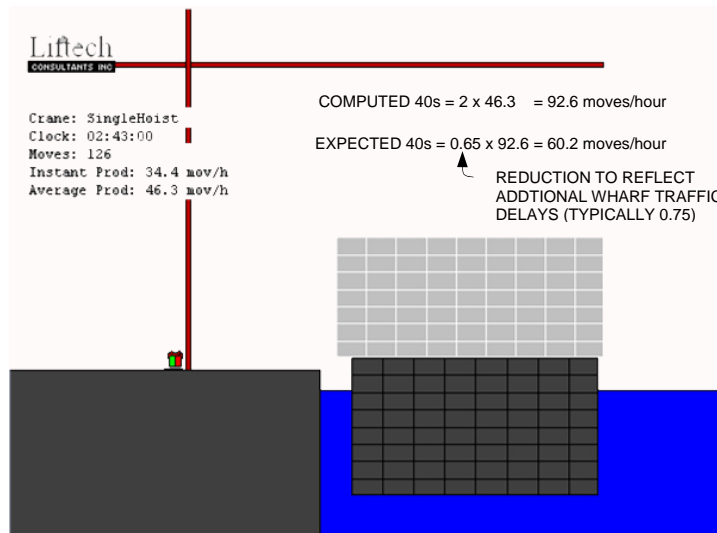

Figure 1. Crane configurations

Productivity

Tandem-40 crane productivity could double that of conventional single-hoist operations if it weren't for the increase in non-crane delays. These delays, however, reduce the productivity increase to about 50 percent—still a significant improvement. Liftech's CraneSim, shown in Figure 2, calculates productivity if there are no delays. Although the production is overestimated, the relationships between various parameters are valid. Typically, the expected production including non-crane delays is about 65 percent of the simulation results.



**Figure 2. CraneSim tandem productivity estimates**

**Operation and Yard Related Issues**

To gain full advantage of the tandem-40 cranes' potential, yard operations need to change. Automation may be necessary to achieve maximum efficiency.

**Wharf and Yard Congestion**

On the wharf, containers are arranged in one of the five patterns, shown in Figure 3. Tandem operations exacerbate congestion and require either two single chassis or one tandem chassis. Tandem chassis shown in Figure 4. Tandem chassis avoid added delays under the crane but require major changes to the yard. Single chassis increase delays under the crane but do not require significant yard changes.

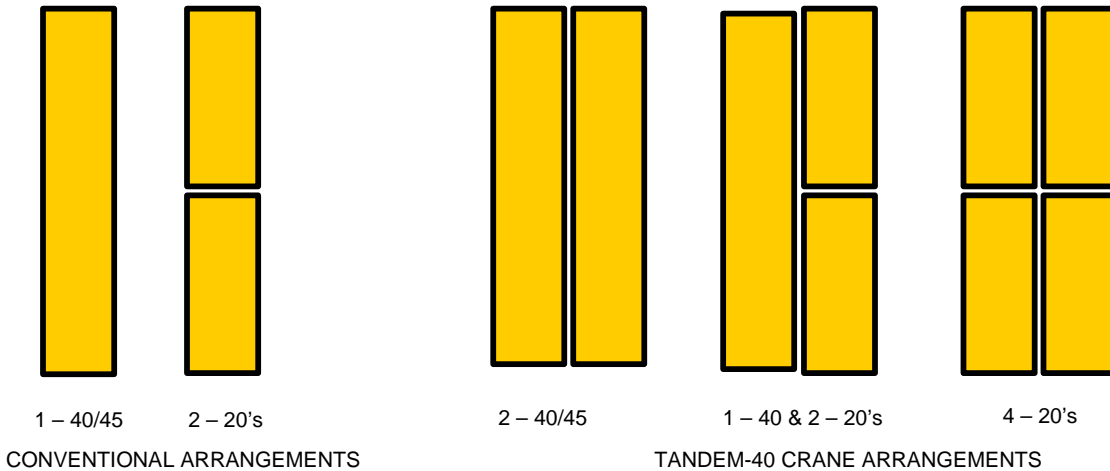

**Figure 3. Container arrangements—Plan view**



**Figure 4. Tandem chassis**

**Inter Box Connectors**

For tandem operations, yard personnel must remove the inner IBCs by working between the two closely spaced containers. The spreader/headblocks separate 1600 mm to provide minimal clearance. Figure 5 shows an example of the IBC removal step.

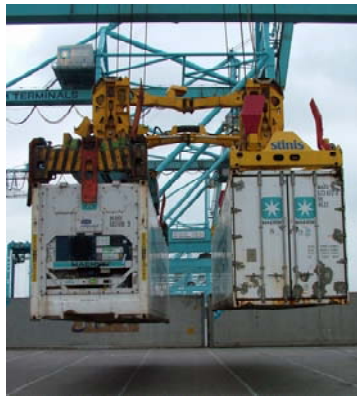

HEADBLOCK SEPARATION



IBC REMOVAL

Photo courtesy of Stinis

**Figure 5. IBC removal step**

On some cranes, an IBC removal work platform is added above the sill beam. This operation increases the crane cycle time, but removes workers from the wharf and reduces congestion on the wharf. If AGVs are used, the platform separates workers from the AGV traffic.

**Crane Weights, Rail Loads, and Rail Gage**

*Crane Weights and Rail Loads*

Tandem cranes are heavier than conventional cranes. The rail loads are also heavier, as shown in Table 1.

**Table 1: Comparison of Typical Conventional and DHT40 Crane Loads**

Item	Conventional Single-hoist Crane	DHT40 Crane
Wheel gage	30 m	30 m
Dead load + trolley	1450 t + 27 t	1850 t + 50 t
Rated load	61 t	80 t
Lifted system; including the headblock and spreader	60 to 85 t	100 to 140 t

---

Factored crane rail load when operating LS/WS	65/80 t/m (1.5 m whl. spacing)	90/110 t/m (1.5 m whl. spacing)
---	-----------------------------------	------------------------------------

---

LS = landside    WS = waterside    1 m = 3.28 ft    1 t = 1 tonne = 2.205 k

*Rail gage*

Increasing the gage beyond the usual 30 meters provides more space under the crane, improves stability, and reduces wheel loads. Several terminals are using gages of 35 m, and one is using 42 m. Figure 6 shows some rail gage arrangements.

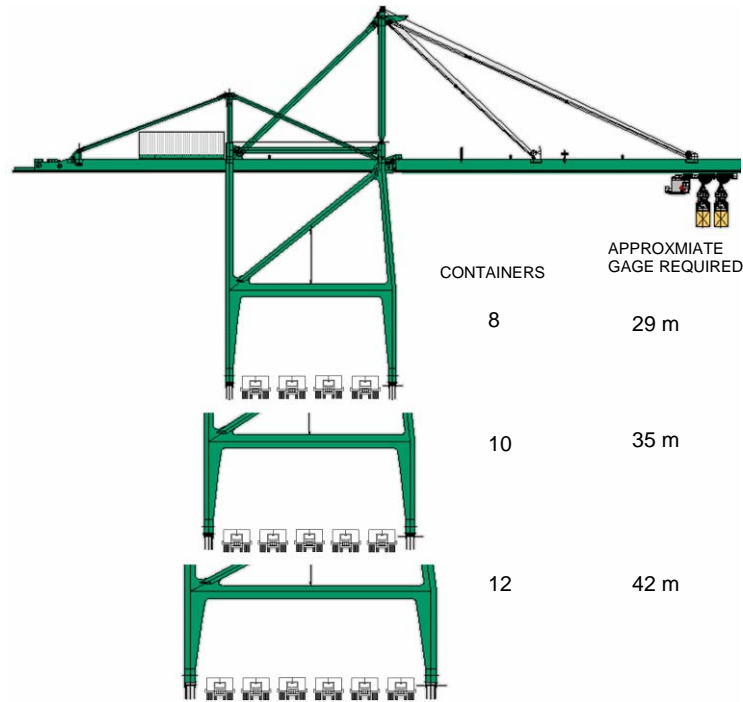

**Figure 6. Rail gage selection**

**Tandem Crane Components**

*Structure*

The heavier rated load obviously requires a heavier crane, but what may not be obvious is the increased fatigue damage caused by heavier tandem loads. This should be considered if existing cranes are to be converted to tandem cranes.

*Machinery House*

The machinery house in an SHT40 crane is similar to a conventional house; however, the house for a DHT40 crane contains two-hoist systems. The second hoist, the one at the bottom of Figure 7, is simply a duplicate of the first hoist. To allow for future DHT operation, the machinery house on a new single-hoist crane can be designed to accept a second hoist later.

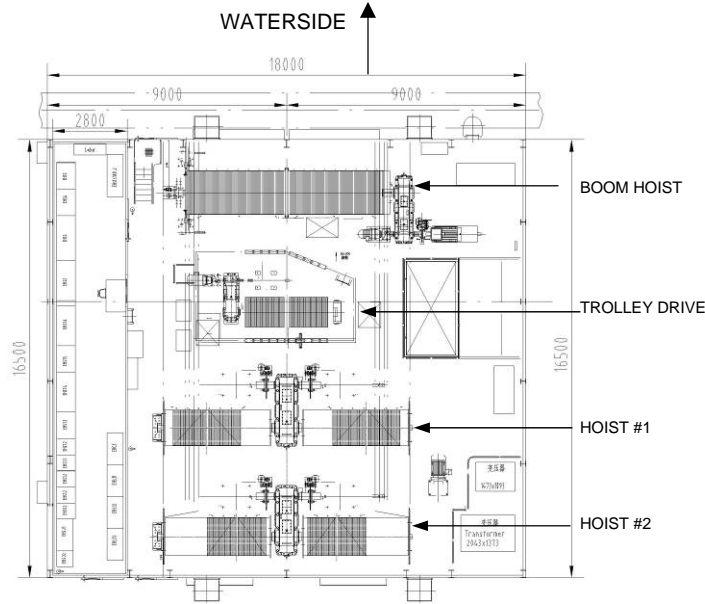

**Figure 7. DHT40 machinery house**

*Trolley*

The SHT40 trolley is similar to a conventional trolley. The DHT40 trolley is very different. Figure 8 shows the latest ZPMC DHT40 trolley. For single-hoist operations, the second headblock is locked into the trolley. For new cranes, the trolley can operate with only one lift system and one set of hoist ropes. The second hoist system can be added later.

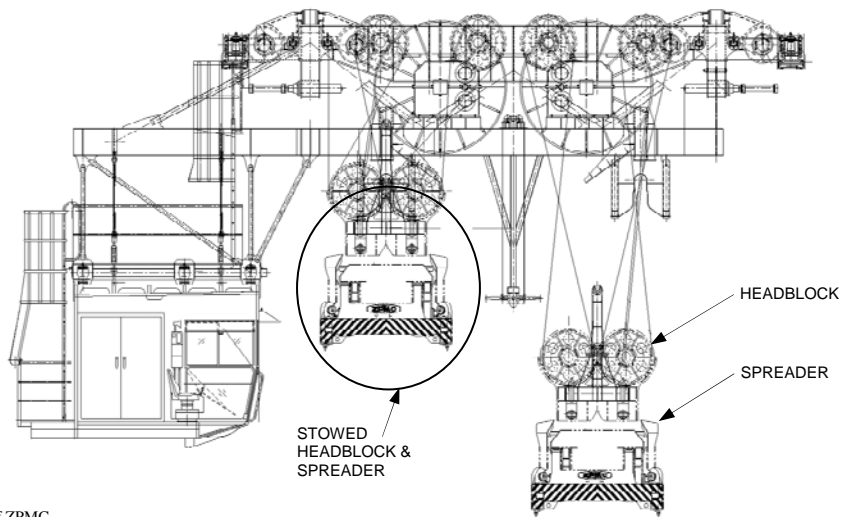

Drawing courtesy of ZPMC

**Figure 8. DHT40 headblock stowage system**

### Headblocks and spreaders

Tandem-40 crane headblocks and spreaders can be single- or dual-hoist. A single-hoist headblock is shown in Figure 9. Single- and dual-hoist lift systems are shown in Figure 10.

The SHT40 spreaders in Figure 9 hang from a single headblock. The sheaves are separated for stability. The hanging load is supported by ropes leading, in the usual way, to a single-hoist drive. The spreaders can translate to accommodate unbalanced loads and single containers.

When the system is in the conventional single-hoist mode, the tandem spreader is replaced by a conventional spreader with the sheaves moved close together. This change takes less than 30 minutes. Typically, the containers can be spread 1.2 m to 1.6 m and can accommodate 300 mm difference in container height.

Bromma, Stinis, and RAM make single-hoist tandem spreaders.

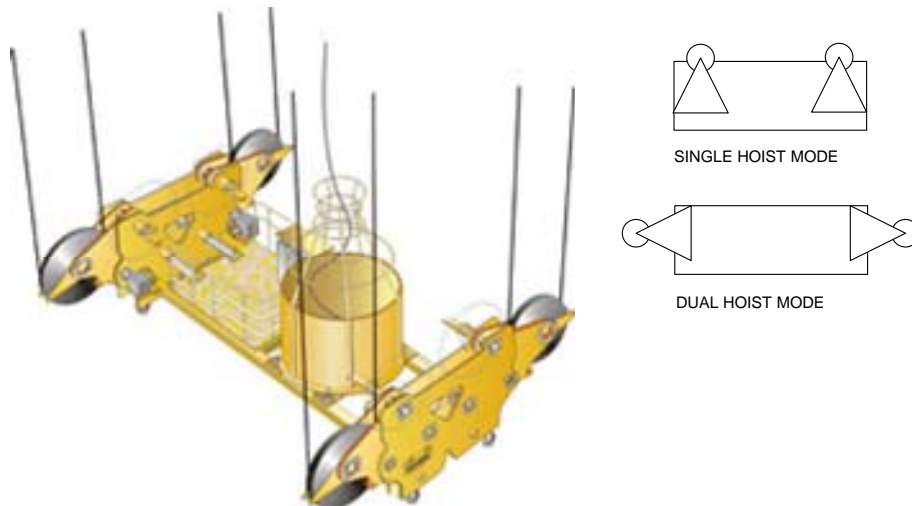

**Figure 9. Single-hoist Bromma headblock—Sheaves separated**

DHT40 headblocks and spreaders are independent and hang on eight ropes—four for each hoist system, as shown in Figure 10; right side. During tandem operations, the headblocks are connected by a headblock coupler. The headblock coupler can adjust the relative positions of headblocks, shown earlier in Figure 5. The spacing can be increased by 1600 mm, the height difference can be 500 mm, and the head blocks can be rotated about all axes. When the headblock coupler is released, each lift system can operate independently.

ZPMC and Bromma have developed dual-hoist headblock designs.





SINGLE-HOIST SYSTEM



DUAL-HOIST SYSTEM

**Figure 10. Dual-hoist Tandem-40 headblock and spreaders**

## Future Developments

### *Triple Tandem*

ZPMC is considering a dual-hoist triple tandem crane, shown in Figure 11. The crane expands a dual-hoist tandem crane by using a “single-hoist tandem lift system” on one of the hoists.

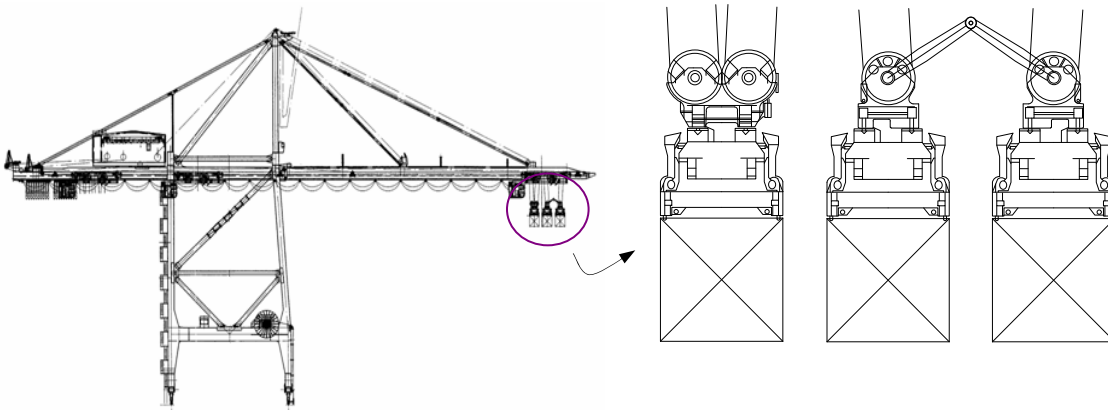

**Figure 11. Triple-40 crane concept by ZPMC**

### *New Terminal Systems*

Other concepts, such as automated cranes or fully automated terminals, may increase productivity even more than tandem-40 cranes. These concepts would require changes to the entire terminal at enormous costs—with significant risks. Consequently, investors approach these ideas with extreme caution. Often, governments help finance such large high-risk projects.

A more affordable and incremental approach to increase productivity is the use of tandem-40 cranes. The investment, although significant, is not nearly as great.



## Conclusion

Dual-hoist tandem-40 cranes are one of the latest innovations to increase crane productivity. Wharf loads will increase. Yard and other operations will need to be improved if the full production potential is to be realized.

Existing conventional single-hoist cranes can be converted to tandem-40 cranes. Although not as versatile as dual-hoist cranes, the conversion can be worthwhile. The terminal will have the option to continue using existing yard equipment and yard layout, or even use the tandem-40s on an existing wharf. If the tandem-40 cranes can not perform at maximum efficiency, they can be converted to conventional cranes.

Tandem cranes have been proven successful and are a practical approach to making incremental improvements for relatively modest costs. Tandem-40 container handling is the future of the container industry.

## Acknowledgements

For their comments and input, the authors would like to thank Mark Sisson, JWD Group/DMJM Harris; Larry Wright, McKay International Engineers, ZPMC, YICT, Bromma, and Stinis.